



Z-Stage 5103.C10

- conversion of horizontal to vertical movement by means of a precision wedge-drive with four linear ball guides
- multi-axis positioning systems possible by simple combination of stages (e.g. with 5102.10, 5203.10)
- use of low-friction plastic slideway high-precision pillar guides results in optimum fine adjustment due to high reproducibility of minimum system step distance
- use of stress-relieved, highly resilient materials guarantees high system stability and long life
- high-precision trapezoidal spindle drive with smoothed and tempered spindle (self-locking)
- robust surfaces through galvanic anodisation
- two precision configurations

Application specific versions:

- vacuum suitable
- antimagnetic
- radiation resistant
- in black

Modularly individually configurable:

- from basic model to high-end system
- to multi-axis systems
- with customer-specific hole pattern

Specifications:

Travel range [mm]:	6
Material (housing/plates):	Aluminium
Spindle pitch [mm]:	0.25
Resolution [μm] (400 steps/rev):	0.625
Max. load [N]:	350
Min. drive torque [Nm]:	0.05
Stiffness [$^{\circ}/\text{Nm}$]:	8
Weight [kg]:	2

Precision configurations:

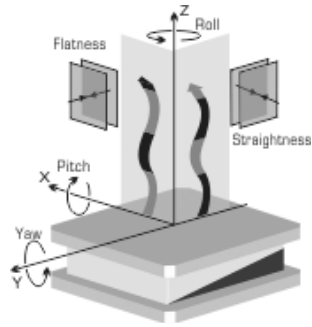

		X1	XE
Accuracy [μm]:	(+/-)	7	on request
Repeatability (unidir.) [μm]:	(+/-)	2	on request
Reversal error [μm]:		10	on request
Flatness [μm]:	(+/-)	9	9
Straightness [μm]:	(+/-)	9	9
Wobble ["]:	(+/-)	14	14
Pitch ["]:	(+/-)	14	14
Roll ["]:	(+/-)	14	14

Maximum load:

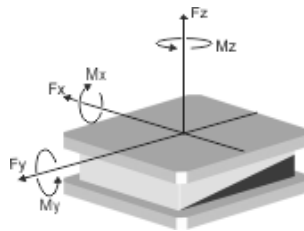

A general statement of maximum load and torque capacities is not possible for eccentric forces due to the amount of different configurations.

However, our engineers will gladly calculate the maximum load capacity for your specific application.

Dimensions [mm]:

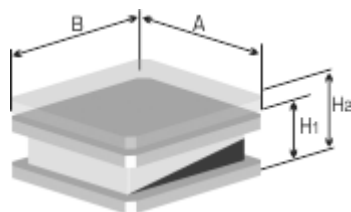

A:	B:	H1:	H2:
100	100	55	55+6

Accessories:

Motors:	2-/5-Ph. Servo/DC
Hand wheels:	0042
Gear boxes:	2042.10 2042.20
Limit switches:	included
Zero-point control:	9100
Encoder XE :	incremental absolute
Control system:	9300

* adaptor required: M301.301-001

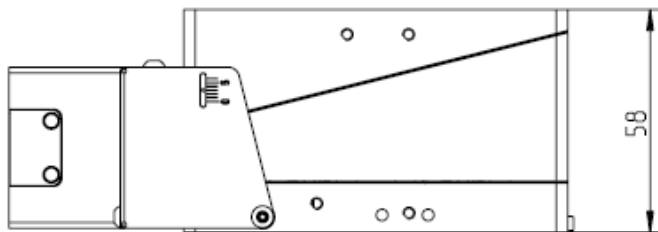
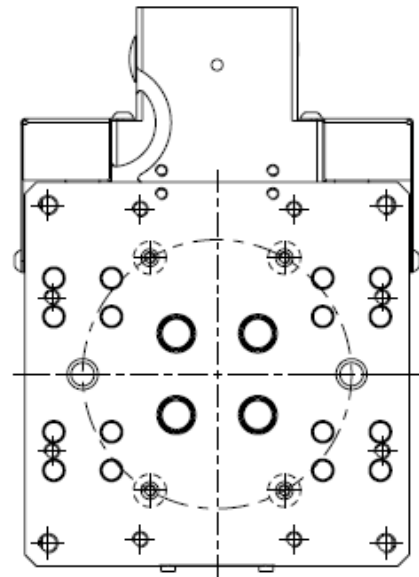
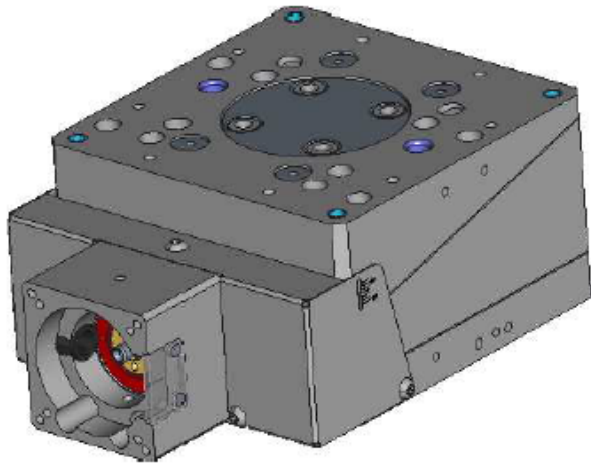

Translation ± 3 mm

